

on_making: 3 Dimensional Computer Modelled Case Studies applied in the teaching of Construction Technology

*"A responsible architecture can only be created through a clear understanding of how it is made. Technology is inseparable from architecture as a whole, and the teaching of these subjects is central to the courses."*¹



Fig 1. Part timber structure study.
Baumschlager + Eberle. Kern House.
Lochau. Austria.

Pivotal to the student's ability to develop an architectural idea is their understanding of construction technology and reciprocally, how it is taught. The capacity to make informed evaluations of materials, structure, scale, form and assembly is inherent to the successful conclusion of a complete design and ultimately an appreciation of how buildings are made. In assisting our pursuit of this we have introduced a supplementary resource to our existing delivery of construction technology teaching in the form of computer modelled building case studies.

The case study method is motivated by an effort to promote student awareness of the position materiality and construction occupy within architectural design. To this end the method aims to avoid potential for a drift toward technology becoming either an idiosyncratic design approach or a residual afterthought when applied in the design studio. We have all experienced the student design project where the adoption of a single technological design strategy has progressed to the detriment or ignorance of the plan, context, scale etc... The opposite is also evident, interesting plan and section but little appreciation of how the building might be structured. These are extreme and happily seldom examples as our teaching aspires to a balance of consideration and inclusion of technology across the course syllabus best described through the school ethos of creative realism.

Advantages of the case study method come to light when considered in conjunction with existing lecture and seminar based teaching. Students can observe the direct correlation between specific knowledge and understanding we impart to them and how it has been applied in a realised piece of architecture. This is in contrast to many textbook approaches where construction principles and ground rules are conveyed through studies of autonomous building parts. Additionally, the case study offers an inclusive building description where the relationships between core technology subject areas of construction, structures, sustainability and environmental design may be observed collectively within the design process.

In principle the case study method is perceived as a positive addition to our customary teaching methodology. However, it should be stressed that this method's success relies fundamentally on the careful consideration of the buildings to be employed. Several factors contribute to the criteria for building choice, they include;

- the requirements of the technology course syllabus and broader course syllabus.
- potential as a vehicle to convey the intended learning outcomes of the syllabus.
- appropriateness of the building's complexity and scale with respect to studio programmes being explored by the student.
- visiting and accessibility opportunities for study visits or personal analysis.
- extent to which building has been reviewed and published in the architectural press offering potential for individual student research.
- potential for the case study contributing to the broader course syllabus, humanities, communications and professional practice.
- availability of detailed technical information to enable the production of the three dimensional computer model. See fig 1.

The availability of building information and details has the most significant influence on the generation of the case study once other factors have been addressed. A number of architectural publications provide sufficient general arrangement and detail information such as the 'The Architect's Journal' weekly technical study or 'Detail' magazine's more broad descriptions of building construction and specification. Ultimately the optimum source of the necessary information is the profession itself and encouragingly the profession has been generous in this provision given the application of the architect's work to an educational context.

One of the first practices we approached with the case study idea was David Chipperfield Architects, London. We were interested in The River and Rowing Museum at Henley (1996), a building conceived and executed by an architect whose attitude captured the spirit of what the case study method of teaching tries to achieve.

'Within our work I see no ideological righteousness in the development of a structural idea, in the materiality of the building, nor in the order of the plan, but rather that in general the architectural project must look for ideas that are engaged with the fundamental issues of making a building. While these concerns in themselves cannot generate an architecture, the dynamic relationship between abstract idea and the material and constructive method is central to the architectural project.'²

At Henley the development of an architectural idea which navigates context, programme, materials, structure and form toward a conclusion can be observed, from inception through to completion. Chipperfield's earliest design sketches for the project intimate an already present consideration of materiality, structure and form. (see fig 2.)

Equipped with general arrangement and specific detail drawings supplied by the practice (see fig. 3) we proceeded to build the detailed three

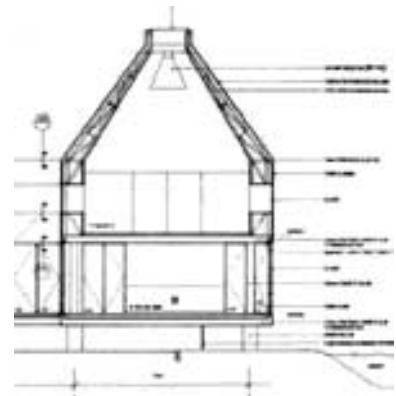

Fig 2. Part general arrangement section through ground and first floor exhibition galleries. Phase one. River and Rowing Museum. Henley. ©David Chipperfield Architects.



Fig 3. computer section model through ground and first floor exhibition galleries. Phase one. River and Rowing Museum. Henley.



Fig 4. computer section model indicating wind load transfer through primary structure. Phase one. River and Rowing Museum. Henley.

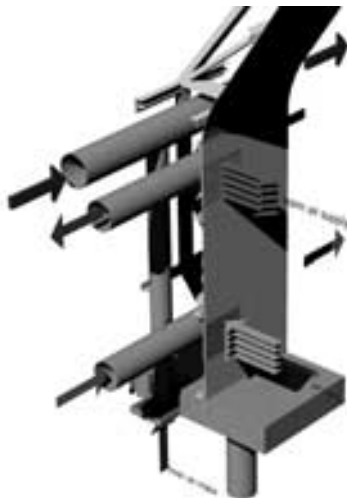

Fig 5. computer cut away study model indicating air conditioning system integration. Phase one. River and Rowing Museum. Henley.

dimensional computer model. In general the information required can be hard copies of dimensioned drawings or more convenient cad drawings which are then translated into a three dimensional wire frame model. Exported to a programme with rendering capability the final model is produced (see fig. 3) forming the common source for generating stills, animation and multi media resource material. The model may then be manipulated to reveal information particular to the user. (see figs. 4 and 7) This process utilises the same software our students encounter in the computing component their communications course. The case study to this end offers one of the core subject areas out with technology an opportunity to see the application of student acquired knowledge and skill.

To appreciate the full potential of the case study method we must consider how and where it is applied within the course delivery.

In the second year of our undergraduate course the students pursue an array of modules over two semesters building on their knowledge gained in year one. Technology, during semester one, concerns itself primarily with the delivery of lecture course based modules covering more complex essentials of construction, structures and environmental science. Construction is presented in a rational sequence of lectures covering foundations, floors, walls, openings, etc and culminating in the characteristics and performance of timber and steel. The module is assessed by formal examination or submitted coursework normally in the form of written papers.

We could describe semester one as the delivery of the subject area theory, however the desired application of this theory by certain students during the semester can expose the lecture course methods limitations. Although we are constantly promoting the application of knowledge acquired through lecture based teaching in simultaneously run studio design projects the duration of the lecture course can be at odds with the demands of a project early in the semester. In addition, studio submissions are not implemented formally in the assessment of the semester one lecture course. This may be a contributory factor in undermining the student's appreciation of the holistic nature of their architectural education. It is in semester two where the advantages of the case study method become apparent.

"Design Technology is concerned with the application of the formally taught knowledge within a contextual architectural design programme. Students are required to demonstrate their ability to design the whole building in detail, showing an understanding of appropriate and sustainable construction / structural systems and environmental control systems. This includes a general awareness of the appropriateness of the fabric design and material used contextually, and the impact these elements will have on the environment and the buildings, formal, functional spatial and aesthetic relationships." ²

Design technology describes the studio module in semester two where students are required to formally³ apply the theory in the development of their studio design project through to detail design. Emphasis on the modules intended learning outcomes is assisted in the control of the programme's complexity with respect to the scale of the project brief. A

limited schedule of accommodation is presented where one component, such as a maximum building footprint, will suggest the use of a two storey design solution which in turn may suggest a structural frame solution. This control enables a more considered and extended phase of research and enquiry during the preliminary stages of the project. During this period the case study buildings are presented in a series of lectures and used as precedent in studio seminars.

The case study lectures present buildings from their inception through to completion. Although under the auspicious of the technology course all design considerations are presented. This is valuable in allowing the student to appreciate the architect's agenda which has informed their choice and development of materials, structure, scale and form. The first seminars are inclusive of construction, structures and environmental design where tutors from the three subject areas meet with groups of students to discuss project development. Emphasis here should be given to the inclusive nature of the seminar. See fig's 5 and 6.

This is deliberate teaching strategy as it introduces the student to the reality of the architectural practice with consultants debating and deliberating over proposed design strategies exhibited in the case study. As students witness debate amongst tutors they are forced to address issues within their project and find their position within the conversation.

Bringing their own research and project development to the discussion in the form of precedent studies, drawings and models we are able to raise considerations and steer their concentration toward achieving a successful conclusion. Large scale models are employed in investigating the components and assembly of their design. Section models at 1:20 through to 1:1 scale models of jointing details are used to explore how their building is made. Student work contributes more significantly to the seminars as the programme progresses as projects develop clarity in the relationships of materiality, construction, structures and environmental strategy. The final submission requirements of the *Design Technology* programme call for information which offers the student the opportunity to exhibit their knowledge and understanding gained during the course of the project. See fig 6.

Fig 6. Café project. 1:20 section model and section drawing. Paul Cumming. Student. Year 2 BSC. 2003.

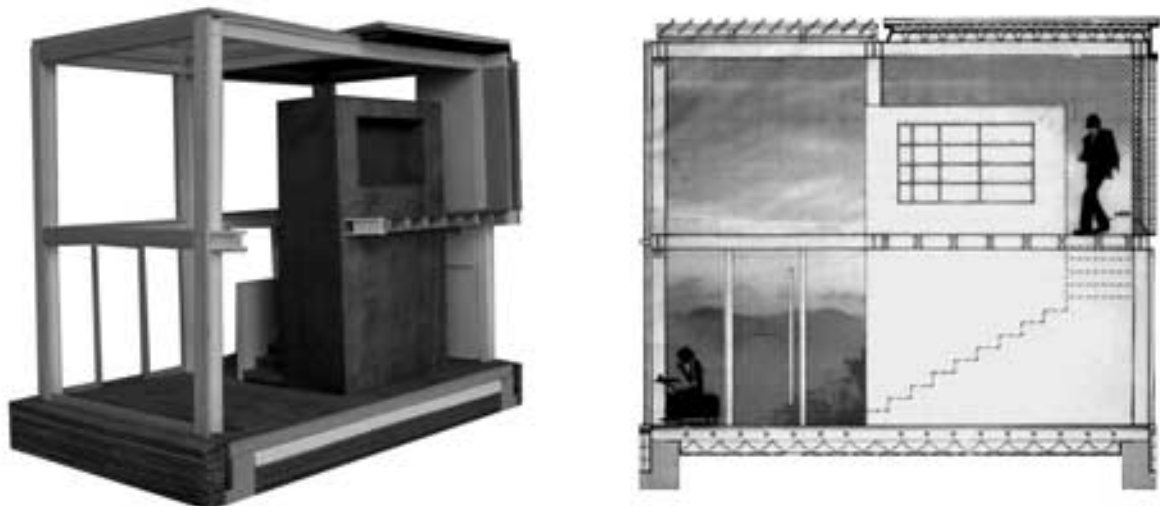

In both the final drawings and models the student is required to exhibit substructure,superstructure, wall, floor, interior finishes and roof components with an accompanying text describing their sequence of assembly. Also, in as far as it is possible, students are encouraged to express the true materiality of the building. The advantage of this is clear in the large scale 1:20 section model which enables the student to experience more vividly the spatial qualities of their design.

The final crit of student work in effect brings the *Design Technology* programme full circle where having set out with the presentation of the building case studies the student in effect arrives back with a case study of their own.

A growing library of case study buildings is being added to each year which our students can access for their own personal research via the school server. We hope to expand this library with the inclusion of student *Design Technology* projects and student authored building studies observed during the construction phase allowing video recording of actual building processes and student on site experience.

To date feedback for the case study method is limited to student staff liaison meetings and end of year questionnaires. Feedback has been positive especially with respect to the inclusive nature of the lecture presentations and seminars. Future development will involve an analysis of the learning and teaching quality of the proposal with a case study presentation of Mount Stuart Visitors Centre, Isle of Bute, Scotland by Munkenbeck and Marshall Architects, London. This will be followed up by a field study visit by a cross section of the student cohort and completion of a subsequent questionnaire.

Reaching further abroad the 'on_making' research group is currently developing a website to promote and share building case studies. With combined professional, academic and student feedback it is hoped our research and development of teaching methods in construction technology will continue.

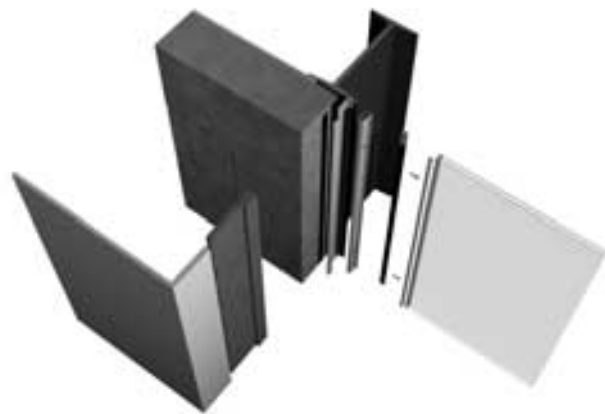

Fig 7. Detail study. Glazing jamb detail. Bramante Architects. Citizen Advice Bureau. Chessington. London.

Notes

1. Programme Review. School of Architecture. Faculty of Duncan of Jordanstone. University of Dundee. 2004.
2. Chipperfield, D. Tradition and Invention. Tectonic form/Making Space. 2G International Architecture Review. David Chipperfield – Recent Work. 1997. p. 140.
3. Burford, N. Design Technology. Course Handbook. Technology. September 2003. School of Architecture. Faculty of Duncan of Jordanstone. University of Dundee.
4. Author's note. Refers to the application of knowledge which will be formally assessed.

References

- Waechter-Bohm, L. Baumschlager & Eberle: Bauten Und Projekte / Buildings and Projects, 1996-2002.
- Shortis, M. Leahy, F. Ogleby, C. Kealy, A. and Ellis, F. The Use of Simulations and Visual Feedback in Learning Spatial Design
And Analysis Concepts. Department of Geomatics. University of Melbourne. 2002.
- Larsen, H. Summer House with Studio in Vejby Simple Forms of Building. Detail. Volume 3. 2001. p. 420 – 425.
- Silvia, F. Ef-Kern House. Lochau (Austria). Baumschlager and Eberle. Materia. 31. May-August 2000. pp. 56 – 65.
- J. Finklestein. (1998) 4D Multimedia Datascape: The SSV Program. Faculty of Architecture, Building and Planning. University of Melbourne.
- C. Newton. (1998) Architecture as Alchemy. Changing documentation languages and their translation into built forms. Faculty of Architecture, Building and Planning. University of Melbourne.
- Forster, W. Tradition and Innovation: timber as rainscreen cladding. Architect Research Quarterly. Volume 2. Summer 1997. pp 54 – 63.
- Chipperfield, D. Museum in Henley-on-Thames, Oxfordshire. Pitched Roof Construction. Detail. Volume 5. 1999. p. 827.
- Gustavo Gilli, G. 2G International Architecture Review. David Chipperfield – Recent Work. 1997.
- Webster, A., Feiner, S., MacIntyre, B., Massie, W., and T. Krueger. Augmented reality in architectural construction, inspection and renovation. Proc. ASCE Third Congress on Computing in Civil Engineering, Anaheim, CA, June 17-19, 1996, 913-919.

Illustrations

- Fig's 1 and 3 to 7. Render images from Rhino' computer model. Christopher Lowry.
- Fig 2. © David Chipperfield Architects.
- Fig 6. Paul Cumming.